

4

3

2

1

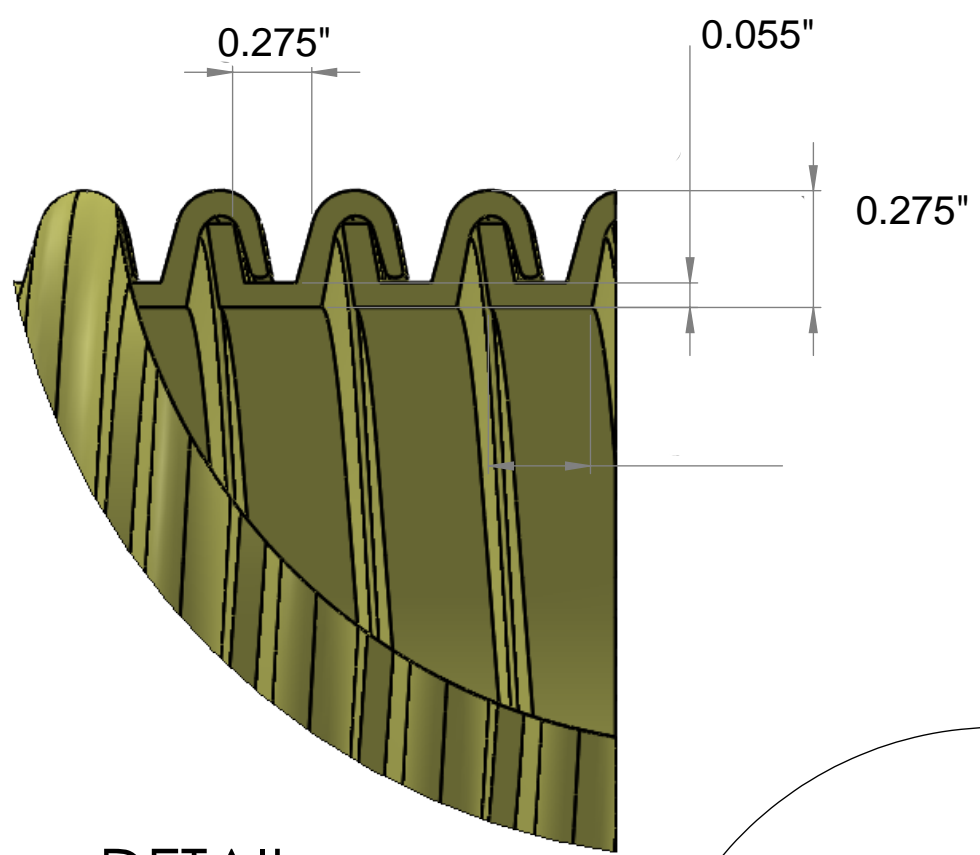

DETAIL A

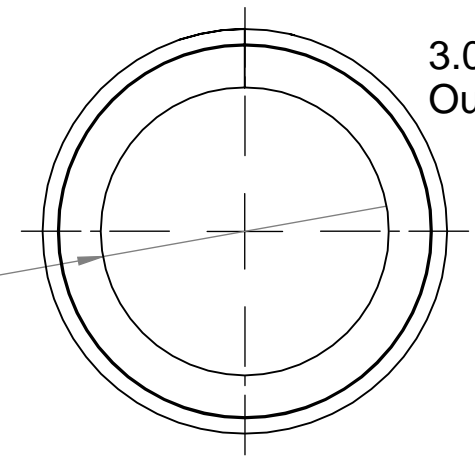
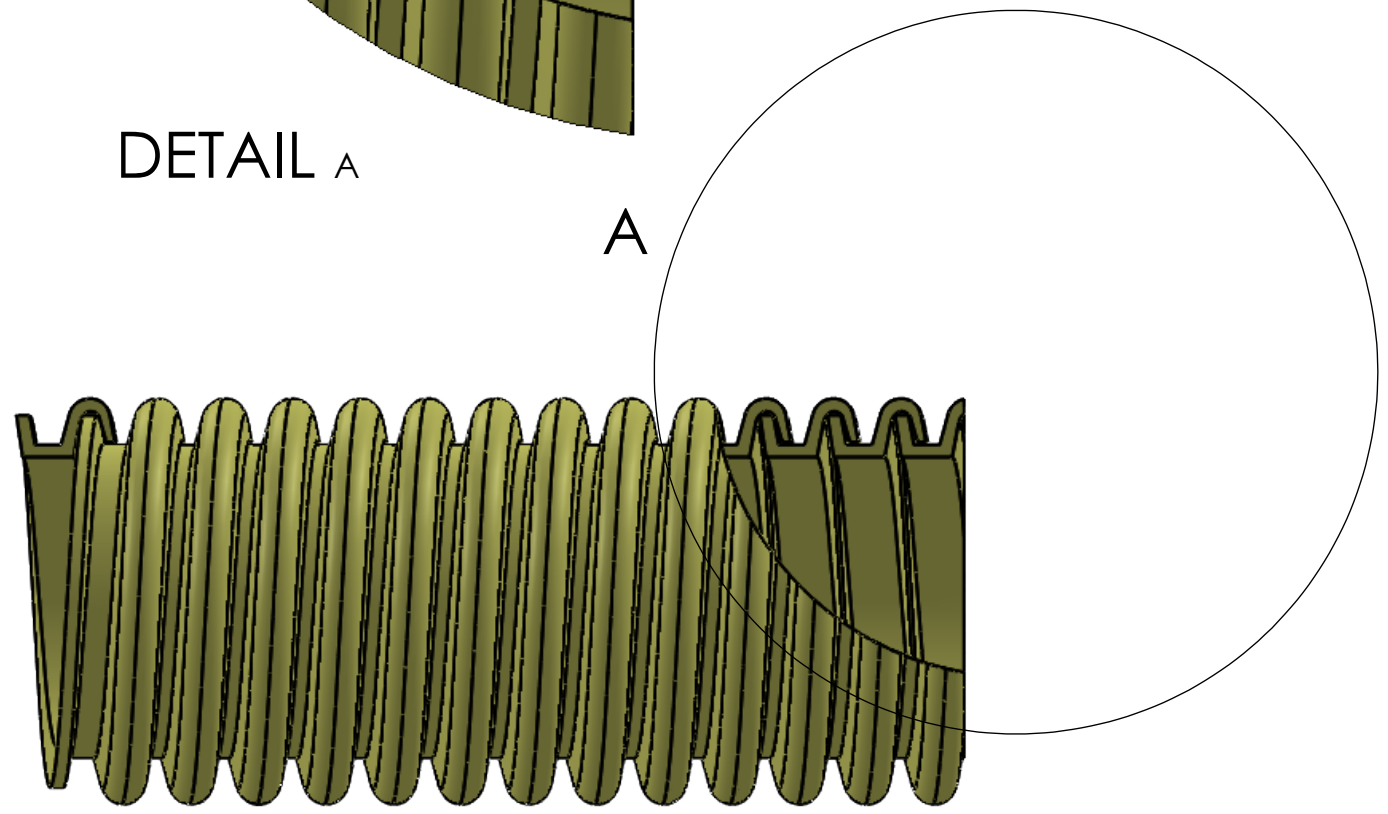
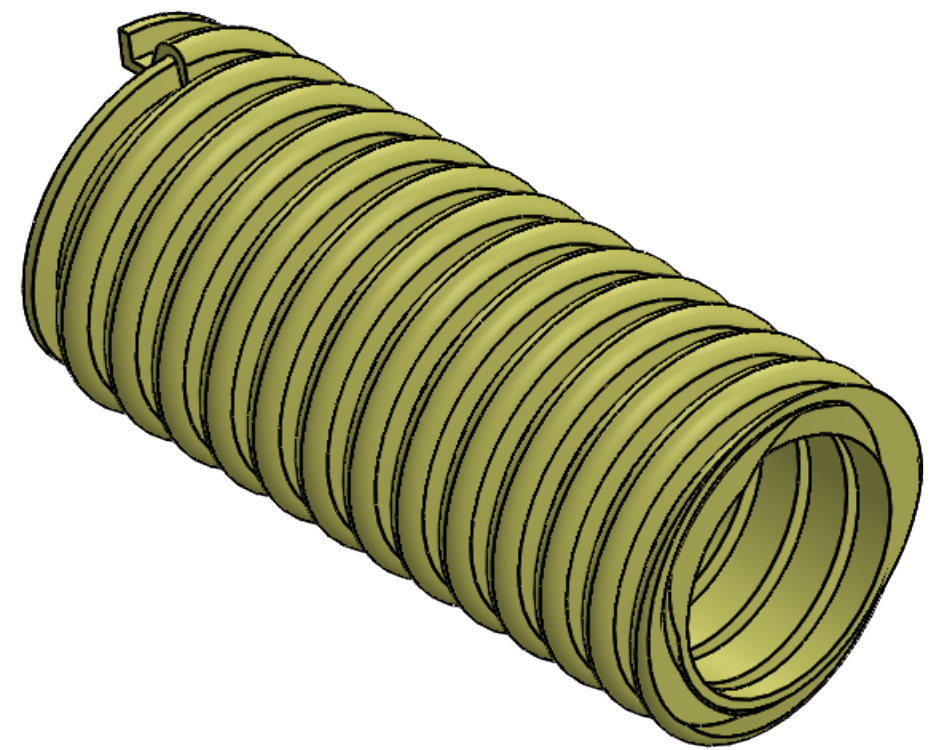

3.050" OD
Outside Diameter

2.50" ID
(Inside Diameter)

		UNLESS OTHERWISE SPECIFIED:		NAME	DATE	AMFLEX PLASTICS INC	
		DIMENSIONS ARE IN INCHES TOLERANCES: FRACTIONAL ANGULAR: MACH BEND TWO PLACE DECIMAL THREE PLACE DECIMAL		DRAWN	ALEJO	08/27/24	TITLE:
		INTERPRET GEOMETRIC TOLERANCING PER:		CHECKED			PREMIER VAC 2.5"
		MATERIAL		ENG APPR.			
		FINISH		MFG APPR.			SIZE
NEXT ASSY	USED ON			Q.A.			DWG. NO.
APPLICATION		DO NOT SCALE DRAWING		COMMENTS:			5PR250X
							REV
							WEIGHT:
							SHEET 1 OF 1

PROPRIETARY AND CONFIDENTIAL
 THE INFORMATION CONTAINED IN THIS DRAWING IS THE SOLE PROPERTY OF AMFLEX PLASTICS. ANY REPRODUCTION IN PART OR AS A WHOLE WITHOUT THE WRITTEN PERMISSION OF AMFLEX PLASTICS IS PROHIBITED.

B

B

A

A

2

1